

**FSP 127mm Signalling Lantern
User Information**

Contents

	<i>Page</i>
USER INFORMATION FOR FSP 127MM SIGNALLING LANTERN	1
INTRODUCTION.....	1
SAFETY PRECAUTIONS	1
TECHNICAL INFORMATION	2
<i>Electrical Characteristics</i>	2
OPERATING INSTRUCTIONS.....	3
SETTING TO WORK.....	3
<i>When fitting the lamp:</i>	3
<i>To replace a lamp:</i>	4
<i>To replace front glass:</i>	4
<i>To replace microswitch:</i>	4
<i>Information for Safe use of Batteries and Chargers</i>	4
<i>Battery Safety</i>	4
<i>Battery Charging</i>	5
<i>Battery Care</i>	5
TESTING THE SIGNALLING LANTERN	6
FAULT FINDING	6
<i>Fault:</i>	7
MAINTENANCE AND SERVICING REQUIREMENTS.....	7
SPARE PARTS LISTS	8
BARREL ASSEMBLY	8
HANDLE ASSEMBLY	9
LAMPHOLDER/SHUTTER ASSEMBLY.....	10
FRONT RING ASSEMBLY	11
BATTERY CASE/TRANSFORMERS/CHARGERS	12
CASE/FILTERS ASSEMBLIES.....	13
SPARE PARTS ORDERING	14
PARTS DISPOSAL	14
SALES AND SERVICE	14
GUARANTEE.....	14

User Information for FSP 127mm Signalling Lantern

It is imperative that this manual is read carefully and fully understood before using your equipment. For your future reference this manual should be kept in a safe place.

Introduction

Thank you for specifying a product from the Francis Searchlights Ltd. range. All Francis products are designed to give complete customer satisfaction and are manufactured to the highest engineering standards in order to ensure optimum performance and service life.

The Francis FSP series of products combine design features proven over many years of service in the most hazardous conditions in marine installations.

In order to prolong the life and performance of your product, we recommend that you only specify Francis Searchlights spare parts. This will also ensure that any warranties on your equipment will not be invalidated. Information on spares ordering and parts is provided in this manual.

Should you ever need to contact Francis Searchlights Ltd. regarding your equipment, please quote the Product Serial Number at all times. Please complete the following boxes for your future reference purposes.

Product Number	Serial Number

Safety Precautions

The following instructions must be adhered to in order to ensure a safe working environment and the safety of the user.

- Prevent rain, snow, condensation and water droplets from contacting the lamp as this may cause bulb failure and possible shattering;
- Care should be taken not to look directly at the illuminated light source;
- Should it be necessary to examine the lamp, always use a protective shield to ensure a safe working environment;
- Never attempt to clean the lamp when in use;
- Ensure that the lamp has cooled sufficiently before removal;
- During the cooling down period avoid mechanical or thermal shock to the lamp as this may cause shattering;

- If undue force appears necessary to remove the lamp, the equipment should be inspected by a competent person, or contact the manufacturer;
- When breaking a lamp for disposal, care must be taken to ensure that all the fragments are safely contained. Precautions must be taken against flying glass and other fragments. This operation should be performed outdoors or in a well ventilated area. In ALL cases reference should be made to the lamp manufacturers instructions packed with the lamp;
- Due to the vast range of lamps available, it may appear possible that more powerful lamps can be used in the equipment than for which it was designed. Even when the unit will physically accept a higher wattage lamp, this substitution is not recommended as it is dangerous;
- Although variations in ambient temperature affect lamp life very little, very high temperatures should be avoided. Very low ambient temperatures have no affect on the performance of filament lamps.

Technical Information

The MKV Signalling Lantern has been designed to Admiralty specification and as such has inbuilt robustness. The equipment is designed as a hand held light unit for use on all craft for ship to ship or ship to shore signalling, utilising Morse code.

The maximum signalling range in daylight is 8 nautical miles (14.8 Km) with a signalling speed of 12 words per minute.

The light output intensity may be varied by attaching coloured filters or a light reduction screen to the front bezel dowel screws. Also, the unit can be used as a spotlight when the switch handle and the trigger are both kept depressed.

Electrical Characteristics

The light signal is powered from either a 12V or 24V dc supply on the vessel or from a portable battery pack. Electrical connection to the light unit is via a pin connector. The light output is derived from either an 11V or 24V 60 watt APFDC P30d lamp. The normal lamp life for these lamps is approximately 100 hours.

The unit can also be operated via a transformer unit for mains operation.

Design Features

Dimensions:	Height: 265mm
	Width: 159mm
	Depth: 240mm

Weight:	2.2Kg
---------	-------

Operating temperature:	+60°C/-40°C
------------------------	-------------

Class of

Enclosure:	IP56
------------	------

Shock Test:	Minimum 30g in 3 planes when housed in stowage box.
-------------	---

Approvals: Fulfils requirements of SOLAS regulations

Approved by UK DoT, Marine Directorate.

Eye protection must be worn when handling lamps that have been removed from their packaging materials.

The equipment should not be modified in any way that will adversely affect the safe operation of the lamp.

Operating Instructions

This equipment is designed for use out of doors, in free air.

Note: *This product should not be used for any other purpose than for which it was designed. Any modifications to the product should not be undertaken before consulting the manufacturer or agent.*

To operate the unit, firstly connect to a suitable supply. Depress the lower switch lever in the handle to switch the lamp on. Signalling is carried out by use of the trigger.

The trigger operates a tubular shutter which obscures the light from the reflector, thus creating an on/off effect.

The sight on top of the signalling lantern contains cross-wires thus enabling the user to aim the light at a specific target.

Setting to Work

Safe service in use necessitates the strict observance of the following precautions.

Any article fabricated from quartz or glass is inherently fragile and care should therefore be taken at all times when handling lamps.

Do not insert or remove a lamp, or open the equipment, unless the equipment is isolated from the electrical supply.

Quartz lamps should not become contaminated with oils, greases or come into contact with the skin.

When fitting the lamp:

- Always isolate the equipment from the electrical supply before inserting/removing a lamp;
- Ensure that the lamp is of the correct type and rating;
- Ensure the lamp is correctly located in the lampholder and that the glass bulb is not scratched during insertion;
- Keep the lamp in its packaging until immediately prior to use;
- Ensure that the fitting and lampholder is in a good dry condition. Never allow water to collect in the lamp fitting or come into contact with the lamp;

- During the insertion of the lamp, special care must be taken in order to avoid too much lateral pressure on the lamp and contacts;
- Ensure that the lampholder is in a good condition. If the contacts show any sign of corrosion the lampholder should be replaced.

To replace a lamp:

- Remove the front bezel assembly by undoing the three captive screws;
- Depress the trigger, thus exposing the lamp;
- Turn the lamp anti-clockwise to remove;
- This procedure should be reversed to replace the lamp.

Note: *It is most imperative that when changing the lamp, the shutter tube should not be depressed from inside the unit. Only the trigger should be used.*

To replace front glass:

- Remove the front bezel assembly by undoing the three captive screws;
- Remove the six screws from inside the front bezel assembly;
- Remove the inner front bezel. The inner and outer gasket seals can now be removed;
- Fit new front glass;
- Reverse this procedure for re-assembly.

To replace microswitch:

- Remove the two large screws in the handle and separate the handle halves;
- The microswitch will now be exposed. Remove the nuts securing the microswitch in its position;
- Remove the screws securing the microswitch leads;
- The microswitch can now be removed and replaced;
- Reverse this procedure for re-assembly.

Information for Safe use of Batteries and Chargers

The following notes should ensure that optimum performance and service life are obtained from the product for many years.

Battery Safety

- Batteries are electrically live at all times. Take great care never to short-circuit the battery terminals;
- Never attempt to remove the battery pack from its' housing, remove the battery lid or tamper with the internal workings. The batteries used are 'low maintenance' requiring no electrolyte top-up or measurement of Specific Gravity;
- When a battery has reached the end-of-life, it must be disposed of correctly. NEVER throw batteries in the bin as they contain harmful substances that damage the environment. NEVER bury batteries in the ground or

incinerate them, as this is unsafe. ALWAYS return the battery to the point of sale, the Local Council tip or any licensed battery dealer for recycling/disposal.

Battery Charging

- Connect charger leads to adaptor plug provided, ensuring RED is connected to the POSITIVE (+) terminal and BLACK is connected to the NEGATIVE (-) terminal;
- Plug charger into mains socket and switch on, observe that one of the two indicators (LED's) is illuminated;
- If the battery is in a state of discharge, the RED 'Bulk Charge' LED will illuminate, indicating that the main battery charging is in progress. As the battery approaches full charge (85 to 95%) the charger will automatically switch down to a float charge voltage, and the GREEN 'Float Charge' LED will illuminate. At this point the battery will be 85 to 95% charged, and may be used. However, it is best practice to keep the battery on charge for a further period of time (2 to 6 hours), in order to charge the battery 100%. This will preserve the life of the battery by preventing 'Sulphation'; IMPORTANT: To ensure maximum service life of your battery, it is essential that a charger specifically designed for the rated ampere-hour capacity is used as failure to observe this notice may damage the battery or charger.

Battery Care

- The recommended operating temperature range is -25°C to 20°C. High temperatures will reduce battery service life whilst low temperatures will help to ensure a long service life but batteries used at low temperatures have a reduced performance;
- Depending upon the depth of discharge, over a thousand discharge/charge cycles can be expected from the battery;
- Correct charging of the battery is essential in optimising battery performance and life. NEVER leave a battery in a discharged state as this will damage the battery;
- Cyclic charging is used in applications where the battery is repeatedly discharged then charged. A higher charging voltage is used but should NEVER be left on indefinitely, as this will overcharge and destroy the battery;
- For optimum performance ALWAYS recharge a battery immediately after discharging;
- The storage or shelf life of the battery is usually between 12 to 18 months at 20°C starting from a charged condition. Never store a battery in a discharged or partially discharged state. Always store in a dry, clean, cool environment. If storage of 12 months or longer is required, supplementary charging will be necessary.

For information on the use of the mains transformer, please refer to the wiring diagram below.

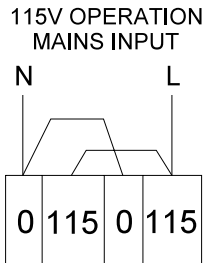
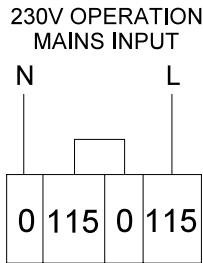

Notes:

1. The transformer is supplied pre-wired internally and only requires connection to the customer supply.
2. Connect supply accordingly, as shown above.
3. Select voltage output via toggle switch on front of enclosure, 12 or 24V as required.
4. Connect signalling lantern to transformer via plug and socket.
5. For safety purposes, only competent personnel should perform the electrical installation.

Testing the Signalling Lantern

Upon correct installation and connection to an electrical supply, the equipment can be tested in order to ensure its' correct performance. This work must be carried out by a competent person with some knowledge of electrical equipment.

Equipment required: Multi-meter with leads;
Ammeter

Using the equation $P=VI$, the approximate power output of the equipment can be calculated in the following way:

- Using the multi-meter take a voltage reading;
- Using the ammeter take a current reading from the live cable to the lamp;
- Multiply these figures together to give an approximate wattage.

For example:

Using a 12V 60w tungsten Halogen lamp,

Voltage reading : 11.8V

Amps reading: 5 amps

Therefore, $P= VI$

$$P= 11.8 \times 5$$

$$P= 59 \text{ watts}$$

Fault Finding

If a fault occurs the following procedures should be adopted. Any work to be carried out should be conducted by a competent person. A multimeter should be used to aid fault diagnosis.

Fault:

Lamp fails to light

Causes:

1. Power not supplied;
2. Microswitch defective;
3. Failed lamp;

Remedy

1. Check voltage at supply/battery. If necessary recharge battery. If no supply is present then fault is at customer supply. If power is present see remedy 2;
2. Check microswitch for failure using multimeter. If found to be defective replace switch following the guidelines for replacement. If microswitch is found to be working correctly, see remedy 3;
3. Check lamp visually for signs of failure. Disconnect from supply and remove lamp following the correct procedures outlined previously in this manual. Re-connect supply and using a multimeter check supply at lampholder. If supply is present, the lamp will have failed. The lamp can also be checked using a multimeter for continuity of the filament. Disconnect supply again and replace lamp following all precautions and procedures mentioned previously, and the lamp manufacturer's instructions. Re-connect supply and test for correct operation.

Maintenance and Servicing Requirements

In order to prolong the service life and performance of your equipment, the

following maintenance guidelines are recommended:

- Maintenance checks should be conducted before every voyage or every three months;
- Before checking, disconnect equipment from the supply;
- Visually check the condition of the equipment;
- Any major or minor structural damage should be rectified immediately;
- After inspection it may be necessary to clean the inside of the unit. The following procedure should be adhered to:
 - Remove the front bezel;
 - Clean the front glass inside and out using a proprietary glass cleaner or methylated spirit;
 - Clean reflector, if required, with glass cleaner;
 - Ensure lampholder is free from corrosion or damage;
 - Check gasket for damage and renew if required;
- Upon completion of these checks, replace the front bezel assembly and test the signalling lantern for full working order.

Note: *It is advisable to check all seals and gaskets for degradation. If replacement is necessary the kit numbers are quoted in the back of the spares lists.*

Spare Parts Lists

Barrel Assembly

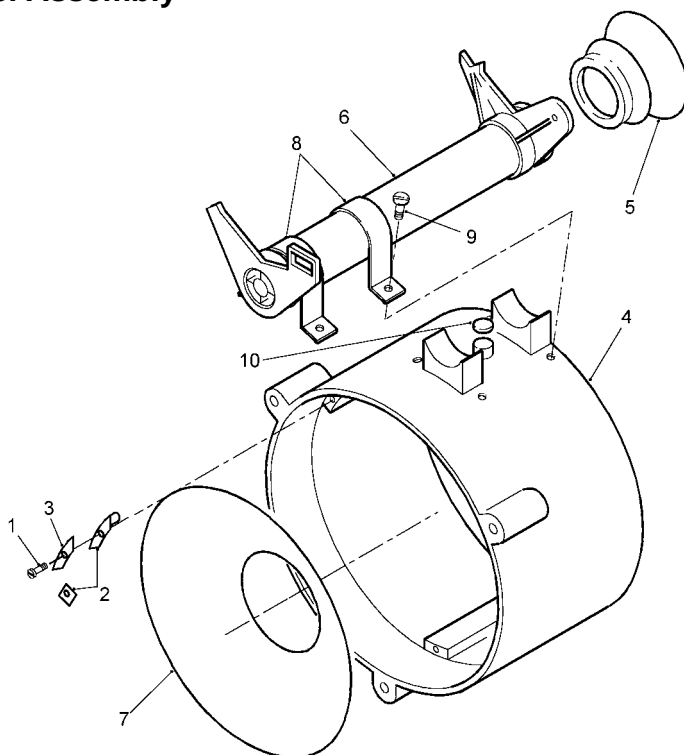

Item No.	Description	Part No.	No. Off
	Barrel Assembly (MOT)	C10548-01	1
	Barrel Assembly (MOD)	C05597-01	1
1	Screw - M3 x 10 Cheese Head (MOD & MOT)	C15141-00	3
2	Mirror Clip (MOT)	C20134-01	3
2	Mirror Clip (MOD)	C05929-00	3
3	Bolting Down Plate (MOD)	C05933-37	3
4	Barrel Sub-Assembly (MOD)	C15192-17	1
4	Barrel Sub-Assembly (MOT)	C15191-17	1
5	Eyepiece	C01461-00	1
6	Sight Assembly (MOD & MOT)	C05598-17	1
7	Reflector (MOD)	C01841-00	1
7	Reflector (MOT)	C21027-00	1
8	Sight Clip	C05602-17	2
9	M4 x 8 C'sk Head	C10231-00	4

Handle Assembly

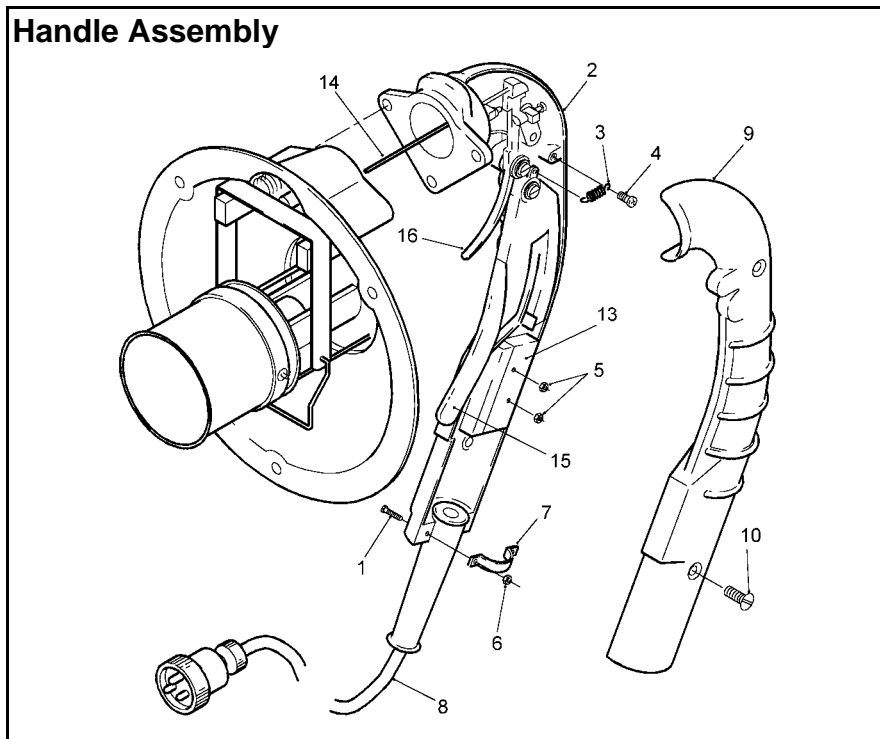

Item No.	Description	Part No.	No. Off
-	Handle Assembly (MOD)	C05618-01	1
-	Handle Assembly (MOT)	C11112-01	1
1	Screw M3 x 16 Pan Head	C10203-00	2
2	Handle	C01010-17	1
3	Switch Spring	C02668-00	1
4	Screw 6-32 UNC x 3/8 in. Pan Head	C03776-00	2
5	Nut M3	C05298-00	2
6	Nut M3	C05298-00	2
7	Saddle	C05939-01	1
8	Cable Assembly (MOD)	C05619-01	1
8	Cable Assembly (MOT)	C03772-01	1
9	Handle cover	C01011-17	1
10	Screw M5 x 25 C'sk Head	C10209-00	2
11	3-pin Plug	C02682-00	1
12	2-pin Plug	C03012-01	1
13	Microswitch	C02103-00	1
14	Push Rod	C05620-01	1
15	Switch Lever Assembly	C01024-17	1
16	Trigger	C01094-01	1

Lampholder/Shutter Assembly

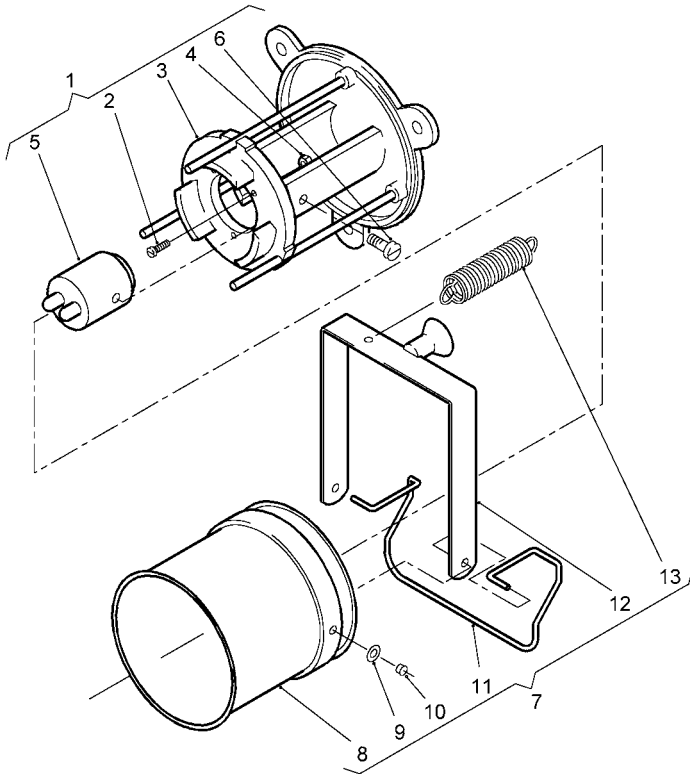

Item No.	Description	Part No.	No. Off
1	Lampholder Assembly (MOD & MOT)	C05606-01	1
2	Lampholder Top Plate Screw	C03034-37	3
3	Lampholder Carrier Assembly (MOD & MOT)	C05607-17	1
4	Nut M3	C05298-00	3
5	Lampholder Body/Leads Assembly	C09715-01	1
6	Screw M4 x 6 Cheese Head	C08011-00	1
7	Shutter Assembly Complete	C05609-01	1
8	Shutter Barrel	C05615-32	1
9	Washer M3	C08028-00	2
10	Eyelet	C06502-00	2
11	Shutter Support Spring	C05613-00	1
12	Shutter Arm Assembly	C05610-37	1
13	Shutter Spring	C02661-00	1

Front Ring Assembly

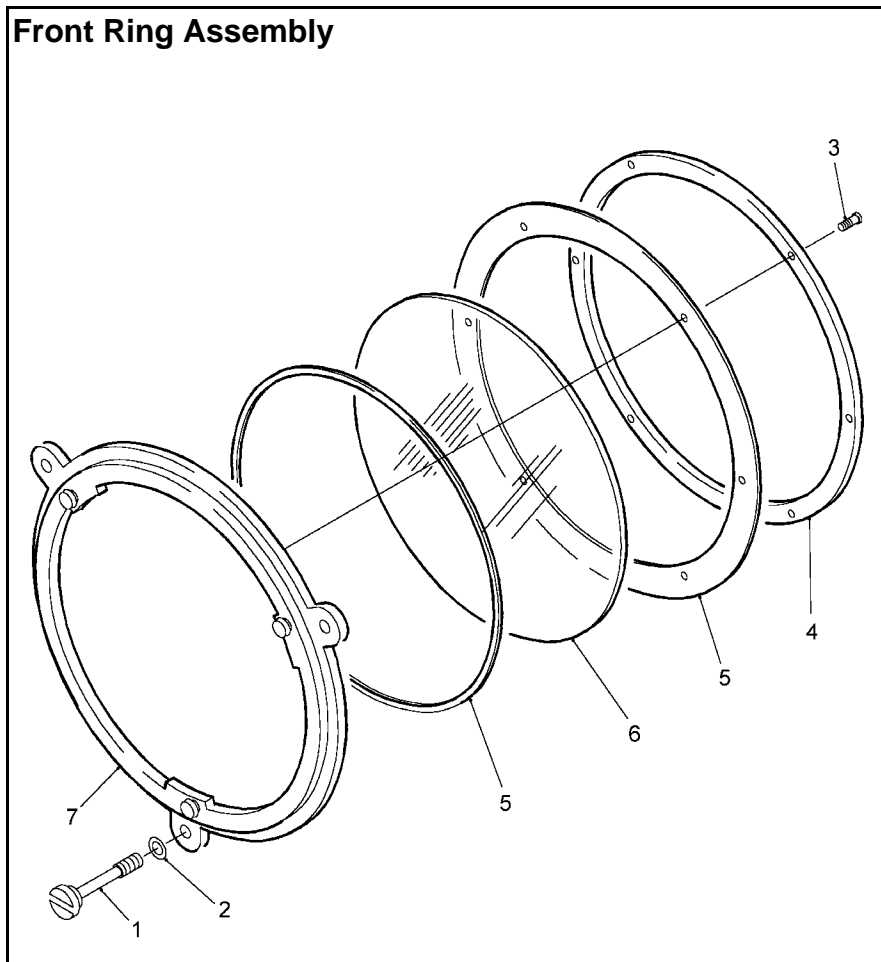

Item No.	Description	Part No.	No. Off
-	Front Ring Assembly Complete	C05603-01	1
1	Front Screw	C02667-01	3
2	Washer M5	C08392-00	3
3	Screw M3 x 10 Cheese Head	C15141-00	6
4	Inner Front Ring	C01028-17	1
5	Gasket Seal Kit	C17105-01	1
6	Front Bezel Glass	C01908-00	1
7	Front Ring Sub-assembly	C11091-17	1

Battery Case/Transformers/Chargers

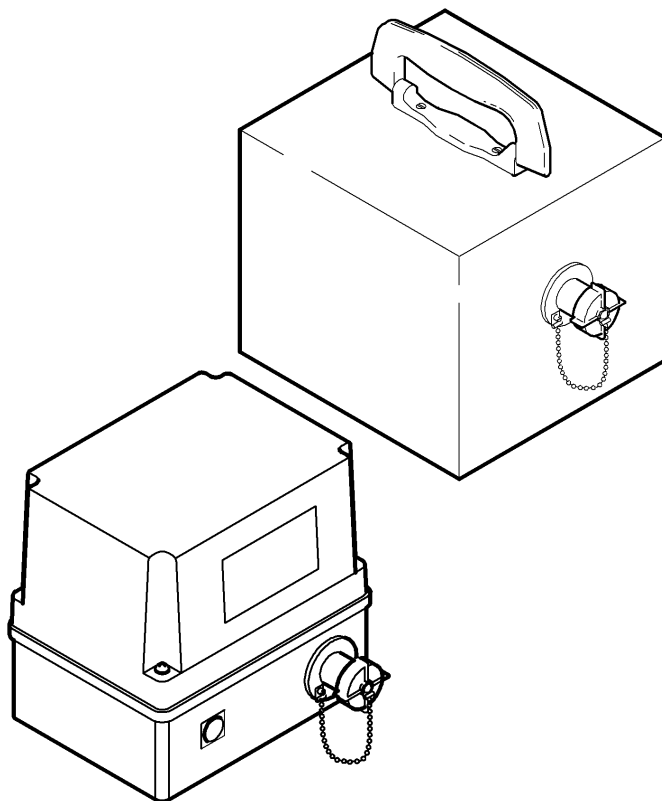

Item No.	Description	Part No.	No. Off
-	12v Battery Box Assembly 2-pin	C20174-01	1
-	24v Battery Box Assembly 2-pin	C20176-01	1
-	12v Battery Box Assembly 3-pin	C20175-01	1
-	24v Battery Box Assembly 3-pin	C20177-01	1
-	Mk V Transformer 115/240v in 12/24v out 3-Pin	C20189-01	1
-	Mk V Transformer 115/240v in 12/24v out 2-Pin	C23619-01	1
-	3 Pin Socket	C02681-01	1
-	2 Pin Socket	C03599-01	1
-	Battery Charger - 115/12v	C20169-00	1
-	Battery Charger - 115/24v	C20170-00	1
-	Battery Charger - 240/12v	C20171-00	1
-	Battery Charger - 240/24v	C20172-00	1

Case/Filters Assemblies

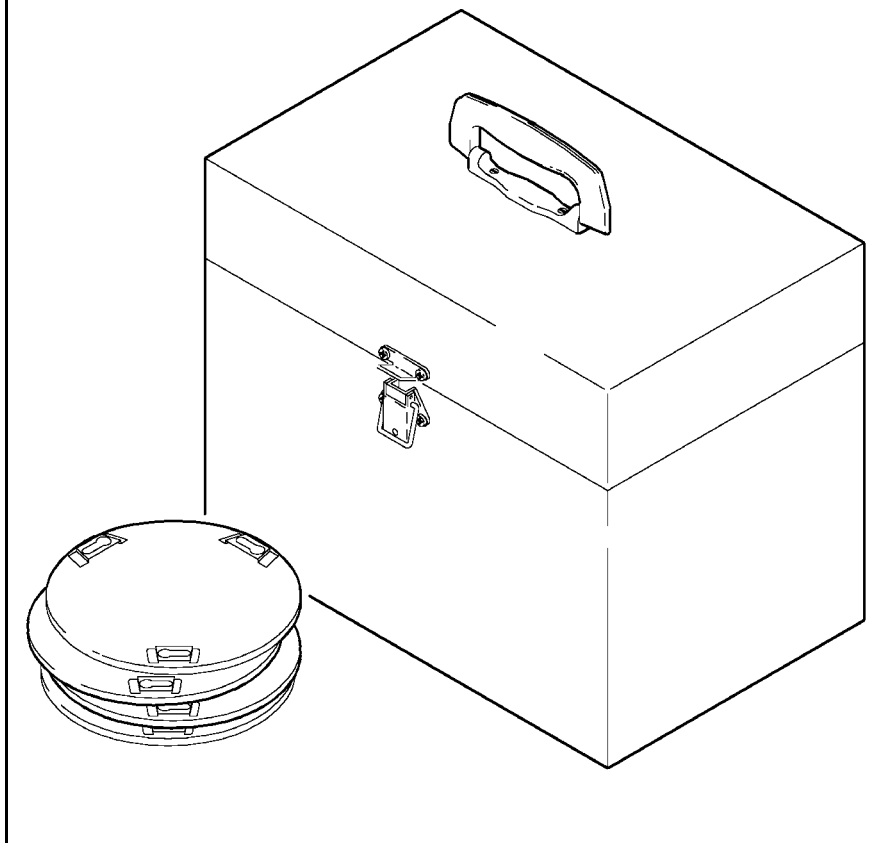

Item No.	Description	Part No.	No. Off
-	Reduction Screen Assembly (MOD & MOT)	C03194-01	1
-	Carrying Case	C01424-18	1
-	Transit Box (MOD)	A4026	1
-	Red Filter Assembly	C05971-01	1
-	Green Filter Assembly	C05973-01	1
-	Blue Filter Assembly	C09901-01	1
-	Yellow Filter Assembly	C21728-01	1
-	Amber Filter Assembly	C23433-01	1
-	Infra-red Filter Glass 900 Nm	C15616-00	1
-	Infra-red Filter Glass 950 Nm	C21536-00	1

Spare Parts Ordering

In order to prolong the life and performance of your equipment it is recommended that only Francis Searchlights Ltd. spare parts are specified. Reference should be made to the relevant spares section in this manual. The part number should be quoted at all times so that a price and delivery time can be supplied.

Spare parts or accessories can be obtained from your distributor/agent or directly from the manufacturer.

Parts Disposal

It is essential that all parts are disposed of correctly and safely to ensure no risk to other personnel. When disposing of lamps the procedures outlined in this manual and the lamp manufacturer's leaflet must be adhered to.

The reworking or modification of parts should not be undertaken before consulting the manufacturer or agent.

Sales and Service

For sales and service please contact your agent/distributor or contact the manufacturer direct at:

Francis Searchlights Ltd
Union Road
Bolton
BL2 2HJ
England

Tel: +44 (0) 1204 558960

Fax: +44 (0) 1204 558979

E-mail: sales@francis.co.uk
<http://www.francis.co.uk>

Guarantee

This product is covered with a 12 month warranty. Any claim whilst under warranty should be addressed to the Quality Manager at Francis Searchlights Ltd.

Agent/Distributor Stamp

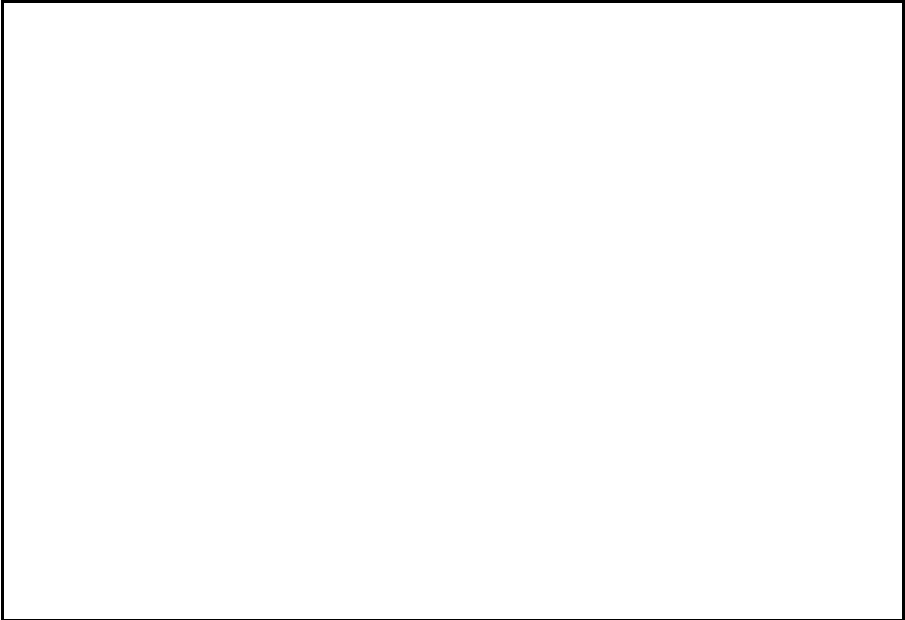

The manufacturer reserves the right to change the information contained within this booklet without prior notice



FRANCIS SEARCHLIGHTS LTD
UNION ROAD, BOLTON, BL2 2HJ, ENGLAND
Tel +44 (0) 1204 558960 Fax: +44 (0) 1204 558979
<http://www.francis.co.uk>

Cert No. 2094
BS5750 Part 1
(ISO 9001)

